

2006 학년도 대학수학능력시험 9 월 모의평가 문제지

외국어 (영어) 영역

concert hall restaurant theater
Railroad Museum Grandma's house

1 번부터 17 번까지는 듣고 답하는 문제입니다 . 방송을 잘 듣고 답을
하기 바랍니다 . 듣는 내용은 한 번만 방송됩니다 .

pleased frightened calm
indifferent irritated

cups boxes newspaper
wallet tape



외국어 (영어) 영역

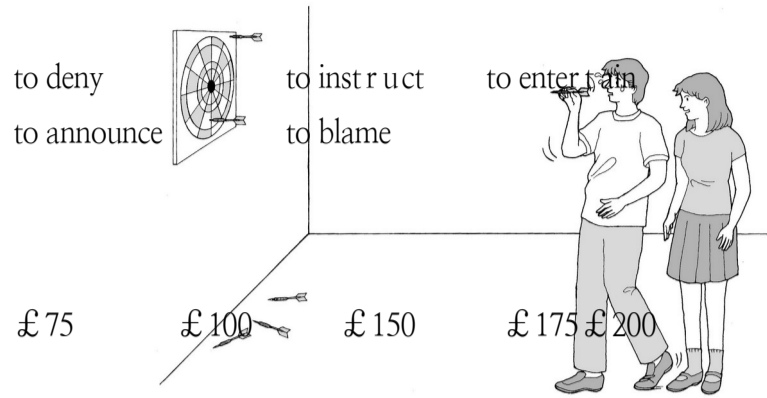

Woman:

train station hotel souvenir shop
post office airport

Man:

\$10 \$15 \$20 \$25 \$30

Woman:

않는 것을 고르시오.

13. 그림의 상황에 가장 적절한 대화를 고르시오.

Alex: Dad,



외국어 (영어) 영역

he 나
him 이 가리키는 대상이
다른 것은?

At

he made every effort
he dropped one shoe by mistake, making a crashing sound in the
silence of the night. Su
him toss and turn
he heard a pounding on the wall and a shout: "When are you
going to drop the other shoe?"

they 가 가리키는 것으로 가장 적절한 것은? [1 점]

Of all animals,

they have most closely shared in human adventures and progress.
For thousands of years, they have participated in the pleasures,
the dangers, and the hard work that have marked human life.
When food became scarce in one area, they helped people move
to more productive areas. They carried people in hunting fields,
in polo matches, and in races. Until the early 1900s they were a
vital part of everyday life. After the Industrial Revolution,
machines did the jobs that they had done, so their population
dropped rapidly.

cows dogs horses
goats pigs

During the last several decades, Asia's glaciers have been melting at an alarming rate. According to Chinese researcher Yao Tandong, annual glacial runoff on the Tibetan Plateau and surrounding areas is roughly 20 percent more than that of 40 years ago. Some of that water is flowing into Asia's rivers, increasing floods and spreading waterborne diseases. In time, the problem will reverse. Yao predicts that 60 percent of the glaciers on the Tibetan Plateau will be gone by the end of the century. "Once the rivers decrease and finally disappear, the cities will dry up and there will be no more cities."

21. (A), (B), (C) 각 네모 안에서 어법에 맞는 표현을 골라 짝지은 것으로 가장 적절한 것은?

Ice hockey is unusual among the major sports in (A) such / that teams frequently play with different numbers of players. Penalties are given for various physical violations that go beyond the sport's permissive rules of contact. Such penalties result in a player being sent to an isolated area called the penalty box, after which the offender's team must operate a player (B) short / shortly . This period of time, when teams have different numbers of players, is called a power play, and provides an excellent (C) scoring / scored opportunity for the larger team.

틀린 것은?

which should allow me plenty of time to turn any questions regarding my decision. I hope that the trip to go smoothly. My experience with you rewarding. I wish you and the organization continued success.

없는 문장은?

Many hands make light work, but at the same time, too many cooks spoil the broth. Which of these contr

biology and behavior are endlessly fascinating. Even for the experienced freshwater aquarist, however, marine fish are considered challenging because it's difficult to keep the seawater quality and temperature stable in an aquarium. Unlike freshwater fish,

외국어 (영어) 영역

many marine species have little

for variations in water quality and temperature. Therefore, keeping them in a home aquarium demands more monitoring and attention to detail.

tolerance
implication

discrimination effect
distaste

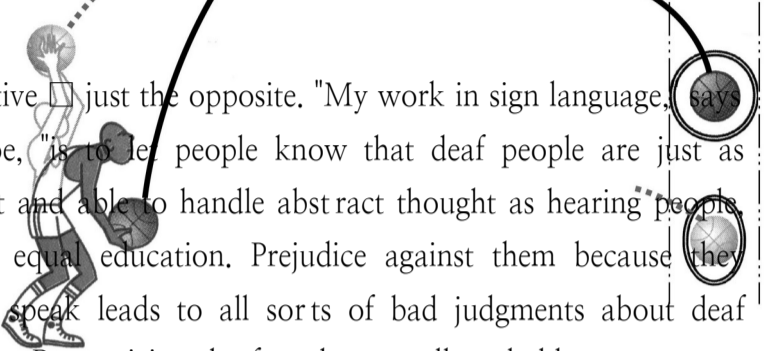

consider sign language primitive □ just the opposite. "My work in sign language," says Stokoe, "is to let people know that deaf people are just as bright and able to handle abstract thought as hearing people, given equal education. Prejudice against them because they don't speak leads to all sorts of bad judgments about deaf people. Recognizing the fact that we all probably owe a great deal to the era when language began

might change some of that. The first language may have been a language not of voices but of signs."

er for warmth, but their sharp needles hurt each other, so they pull away. But then they get cold. They have to keep adjusting their closeness and distance to keep from freezing and from getting hurt by other porcupines. Likewise, we need to get close to each other to have a sense of community, but we need to keep our distance from each other to preserve our independence. This duality reflects the human condition: We need other people to survive, but we

* porcupine: 고슴도치

□

□

□

Rick Barry, once a pro basketball player, was famous for his underhand style for "free throws." While Barry could easily sink nine out of ten shots, others, throwing overhand, fell far short. The key to his accurate free throws lies in the arc of the ball. "Because of the angle into the basket with a typical overhand throw, there is a smaller window for the ball to go in," says Brancazio, a physics professor. "If the ball comes down at the basket from above □ as when tossed up in a high arc, characteristic of an underhand throw □ there's a far

."

* arc: 호(?), 포물선

27. 그림과 설명을 참조할 때, 빈칸에 들어갈 말로 가장 적절한 것은? [3 점]

않은 것은?

Oil prices are at record highs because of short-term concerns over the secu

supplies. Wi
down again. But in the longer ter
declining and there are probably no massive oil fields left. In the past, oil companies pu
abundant, the pressu
unlock this black gold.

외국어 (영어) 영역

Many students are anxious about taking tests. While a little anxiety sharpens the senses, too much can make a person extremely nervous and make clear thinking difficult. You can control test anxiety by being (A) preferred / prepared . Make sure you review your material thoroughly, well in advance of the test. Not only will this help to reinforce information, but it will also boost your (B) confidence / conference . Getting a good night's sleep before the test and eating a nutritious breakfast will (C) enclose / enhance your alertness and help you to feel relaxed.

The word *paradigm* stems from the Greek word *paradeigma*, which means pattern. Originally it was a scientific term but is commonly used today to mean perception, assumption, theory, or frame of reference. It's like a map of a territory. An accurate paradigm explains and guides. But if inaccurate, it can be harmful.

(A) _____, though history books talk about George Washington dying of a throat infection, he probably died of bloodletting.

(B) _____ the paradigm at that time was that bad stuff was in the blood, his doctor took several pints of blood from him in a twenty-four-hour period!

31. 다음 글에서 필자의 주장으로 가장 적절한 것은?

We all make mistakes, have to deal with challenging colleagues, and face situations we are trying to turn around. At times it's so overwhelming that you have no understanding of the situation. Small pains seem monumental, and important things get pushed aside as if they were insignificant. It's not just that you can't see the forest for the trees; you're stuck down there, covered with leaves. Here's what to do. Rise above it. Rise so far above it that you feel 10,000 feet off the ground. Then you will have the insight you need to sort it all out. You will see what really matters in life.

It is truly an honor to have received the Fisher Scholarship for 2003–2004. I am flattered to have been chosen to receive this scholarship. I think chemistry is an interesting field, full of opportunities. I am proud of being a chemistry major here at Roanoke College. I look forward to beginning a career in the chemical industry or perhaps in education. Because of your financial support, I have had the opportunity to receive a wonderful education. I hope that you will continue to support academics at Roanoke College.

grateful regretful embarrassed
curious irritated

[33~34] 다음 글의 주제로 가장 적절한 것을 고르시오.

_____m, you probably have smelled ozone. Its odor is unmistakable, but hard to describe. Ozone is oxygen that has undergone rearrangement from the normal diatomic molecule (O₂) to a triatomic form (O₃). A simple chemical equation summarizes the reaction: 3O₂ + Energy → 2O₃. Energy must be added for this reaction to occur, which accounts for the fact that ozone forms when oxygen is subjected to electrical discharge, whether from an electric spark or lightning.

외국어 (영어) 영역

They sometimes alter their consumption decisions depending on the "play" they are in.

The criteria that they use to evaluate products and services in one of their roles may be quite different from those used in another role. In many cases, the purchaser and the user of a product might not be the same person, as when a parent picks out clothes for a teenager. In other cases, another person may act as an influencer, providing recommendations for or against certain products without actually buying or using them. [3 점]

by chickens, rabbits, squirrels, and birds. Mason recalls that she didn't care much for dolls as a little girl, but that she was fond of dressing up her favorite chickens in miniature clothes. "We had some very patient chickens," she laughs. In college, Mason majored in ethology, the study of animal behavior. Today, her fascination with animals plays a major role in her artistic life. She combines her knowledge about animals with humor in her bronze sculptures. "Some people think art has to be about anxiety, but I'm trying to give the viewer a little something to smile about."

않는 것은?

In ancient China, people, when presenting themselves before a superior, knelt down and bumped their heads on the floor. The "kowitz" ceremony was most commonly used in religious ceremonies when people came to make a request of the priest, or when foreign government officials appeared before the Chinese emperor. The word *kowitz* developed from a combination of two Chinese words, a verb meaning "to knock" and a noun meaning "head." Although British officials were resistant to kowitzing to the Chinese emperor, they did not object to the word, and by the early 1800s *kowitz* had become an English word for showing respect to another person.

36. Diane Mason 에 관한 설명 중, 글의 내용과 일치하지 않는 것은? [1 점]

Sculptor Diane Mason grew up in rural Illinois, surrounded



외국어 (영어) 영역

[38~39] 다음 글의 요지로 가장 적절한 것을 고르시오.

Information, older people are at no disadvantage. A recent study shows that aging does not affect the amount of material you can absorb in a given period. And once you've learned it, you'll probably retain it as well as a younger person. The better educated you are — and the more you continue to learn new things — the greater the likelihood you'll maintain high cognitive functioning.

* cognitive: 인지적인

influenced by several forces in our relatively safe and comfortable modern world. Movies and television programs confirm the illusion that all problems can be easily solved and that life should be safe and wonderful. We don't like to face the truth that uncertainty is a part of life. The tendency to look for someone to blame when something goes wrong implies that accidents "should not" occur. We demand that our medicine, transportation, food, and everything else be 100% safe. This is impossible.

The Big Friendly Giant expressed a wish to learn to read.

[41~42] 다음 글의 제목으로 가장 적절한 것을 고르시오.

When people in the future look back on 2005, what tool will they marvel that we functioned without? What devices will become commonplace that nobody has yet imagined? People capable of dealing with the future and the changes it holds are those who do not fear change and who practice flexibility. Your job will not be the same in twenty years. It just means you need to embrace innovation; otherwise you will not stay on top.

lifestyles that are well above world standards. In recent years, however, an increasing number of Australians have concluded the pursuit of the dollar has been at the expense of happiness and well-being and have chosen to cut their working hours and income. This has been named "downshifting." This decade, nearly a quarter of Australians aged 30 to 59 have downshifted. To downshifters, it is a fair balance between income and free time that they try to achieve.

I lectured for about half an hour. Then, I notice that the students are beginning to look at the ceiling; one is feeling for his handkerchief; another shifts in his seat; another smiles at his thoughts, and so on. This means they are distracted. Something must be done. Taking advantage of the first opportunity, I make a joke. A broad grin comes on to a hundred and fifty faces, the eyes shine brightly, and the thunder of laughter is audible for a brief moment. I laugh, too. Their attention is refreshed, and I can go on.

lively

boring

exciting

peaceful

quiet

44. 주어진 글 다음에 이어질 글의 순서로 가장 적절한 것은?

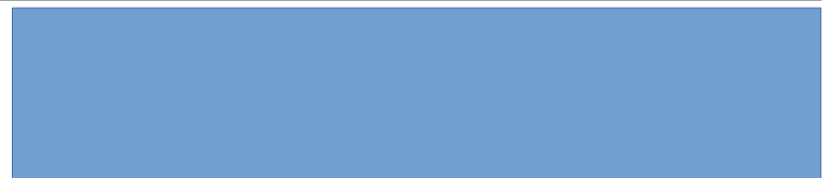

외국어 (영어) 영역

- (A) - (B) - (C) (A) - (C) - (B) (B) - (A) - (C)
 (C) - (A) - (B) (C) - (B) - (A)

to the level of the soul. If I had not met Shawn, I might never have developed my love of literature and writing. And if my father had acted differently, I might have become a journalist. I appreciate both Shawn and my father who led me to the life I enjoy so thoroughly today.

My father's dream for me, however, was that I should become a physician. When we sat down to discuss it, I told him, "No, I don't want to be a doctor. I have no interest in medicine. I want to be a great writer one day." Not long after, on my fourteenth birthday, my father gave me some great literature to read, including *Of Human Bondage* by W. Somerset Maugham, *Arrowsmith* by Sinclair Lewis, and *Magnificent Obsession* by Lloyd C. Douglas. Although he didn't mention it at the time, all these books were about doctors. And they made such a deep impression that they sparked in me a desire to become

one myself.

- (A) - (B) - (C) (A) - (C) - (B) (B) - (C) - (A)
 (C) - (A) - (B) (C) - (B) - (A)

one 이 나타내는 것은?

- a teacher a librarian a psychologist
 a doctor a journalist

Shawn 은 필자의 영향으로 작가가 되었다.

[46~48] 다음 글을 읽고, 물음에 답하십시오.

When I was in school, my best friend was a young fellow called Shawn. He was very skilled at using words. In English class, whenever we had to write an essay, he always received the highest mark. Spending time with him was also great fun. Whatever Shawn did, I wanted to do, too. When Shawn decided to pursue writing as a career, I made the same choice.

Becoming a physician seemed to me to be an ideal way to begin to explore the human mind. I thought that by understanding the mysteries of the human body, perhaps I could someday get down

* 확인 사항

- 답안지의 해당란에 필요한 내용을 정확히 기입 (표기) 했는지 확인하십시오 .

[49~50] 다음 글을 읽고, 물음에 답하시오.

I have a friend who spent most of his adult life insisting he couldn't write a book. This was very puzzling to me, because not only was he an excellent writer, but he also felt quite comfortable writing articles and chapters! One day I asked him to consider the idea that a book is nothing more than a series of interesting chapters put into sequence. Obvious as this was to me, he had never thought of it in those terms. Instead, he had always focused on the stubborn belief that writing a book was too big a project. This simple shift in thinking made all the difference. Two years later, he (a)

his first book.

A giant truck got stuck under an overpass. The truck was too tall for the available clearance. The police called out the best, brightest, and most expensive engineers in the city to try to figure out what to do. They brought along their computers, clipboards, and calculators. They discussed the issue for hours. They simply couldn't figure out how to remove the truck without damaging the freeway above. Then a small boy, about seven years old, walked up to the men. "Excuse me, sir," the little boy said in a respectful tone. "Why don't you just let the air out of the tires?" Out of the mouth of a young boy, the problem was (b)

